

Selective flocculation and floc-flotation of iron bearing mineral slimes

Floculação seletiva e floto-floculação de lamas ferríferas

Floculación selectiva y floto-floculación de fangos férricos

Recebido: 21/03/2022 | Revisado: 28/03/2022 | Aceito: 07/04/2022 | Publicado: 12/04/2022

Pedro Lopes Bretas

ORCID: <https://orcid.org/0000-0002-1604-9461>

Haver & Boecker, Brazil

E-mail: pedrocec2005@yahoo.com.br

Otávia Martins Silva Rodrigues

ORCID: <https://orcid.org/0000-0003-2328-5398>

Universidade Federal de Ouro Preto, Brazil

E-mail: otaviarodrigues@ufop.edu.br

José Aurélio Medeiros da Luz

ORCID: <https://orcid.org/0000-0002-7952-2439>

Universidade Federal de Ouro Preto, Brazil

E-mail: jaurelio@ufop.edu.br

Abstract

The mineral processing of friable iron ores usually generates ultrafine (smaller than 15 μm) particles, normally called slimes, which usually have a high iron grade and are usually disposed into tailings dam. The traditional mineral process techniques for iron ore do not work efficiently with ultrafines; however, selective flocculation is an alternative to concentrate that fraction. The physical-chemical treatment of iron ore slime was studied here, on a bench scale, based on the scientific foundations of selective flocculation and flotation. Samples of slimes from two Brazilian iron ore processing plants (CEII and VGII) and industrial process waters were used in the tests. Complexometric titration of calcium and magnesium indicated that the process waters were adequate for selective flocculation. Only selective flocculation, even under optimum conditions, did not achieve good results. However, its use prior to flotation led to promising results. The VGII sample has stood out, for which the final concentrate achieved 60.1 % of Fe, the mass recovery was 64.5 % and 13.5 % of Fe in the tailing, resulting selectivity index of 6.58, only with one stage of selective flocculation and one stage of flotation.

Keywords: Selective flocculation; Iron ore; Flotation; Ultrafine.

Resumo

O beneficiamento de minérios de ferro friáveis geralmente gera partículas ultrafinas (menores que 15 μm), normalmente chamadas de lamas, as quais usualmente possuem alto teor de ferro e geralmente são dispostas em barragens de rejeitos. As técnicas tradicionais de processamento de minério de ferro não funcionam de forma eficiente para ultrafinos, porém a floculação seletiva é uma alternativa para concentrar essa fração. Estudou-se, aqui, tratamento físico-químico de lama de minério de ferro, em escala de bancada, a partir dos fundamentos científicos de floculação seletiva e flotação. Amostras de lamas de duas usinas brasileiras de processamento de minério de ferro (CEII e VGII) e águas de processo industrial foram empregadas nos ensaios. A titulação complexométrica de cálcio e magnésio indicou que as águas de processo eram adequadas para floculação seletiva. Apenas a floculação seletiva, mesmo em condições ótimas, não obteve bons resultados. No entanto, seu uso antes da flotação levou a resultados promissores. Destacou-se a amostra VGII, para a qual o concentrado final atingiu 60,1 % de Fe, a recuperação de massa foi de 64,5 % e 13,5 % de Fe no rejeito, resultando índice de seletividade de 6,58, apenas com um estágio de floculação seletiva e um estágio de flotação.

Palavras-chave: Floculação seletiva; Minério de ferro; Lamas; Flotação; Ultrafino.

Resumen

El procesamiento de menas de hierro friables generalmente produce partículas ultrafinas (menores a 15 μm), normalmente llamadas fangos o lodos, que generalmente tienen un alto grado de hierro y generalmente se eliminan en presas de relaves. Las técnicas tradicionales de procesamiento de menas de hierro no funcionan de manera eficiente con los ultrafinos; sin embargo, la floculación selectiva es una alternativa para concentrar esa fracción. Se estudió el tratamiento físico-químico de lodos de mineral de hierro, a escala de banco, a partir de los fundamentos científicos de la floculación y la flotación selectivas. En los experimentos se utilizaron muestras de lodos de dos plantas de procesamiento de menas de hierro de Brasil (CEII y VGII) y aguas de procesos industriales. La titulación complexométrica de calcio y magnesio indicó que las aguas del proceso eran adecuadas para la floculación selectiva. Sólo la floculación selectiva, incluso en condiciones óptimas, no logró buenos resultados. Sin embargo, su uso antes de la flotación condujo a resultados prometedores. Se ha destacado la muestra VGII, en la que el concentrado final alcanzó

60,1 % de Fe, la recuperación de masa fue de 64,5 % y 13,5 % de Fe en el relave, resultando un índice de selectividad de 6,58, solo con una etapa de floculación selectiva y una etapa de flotación.

Palabras clave: Floculación selectiva; Mena de hierro; Fango; Flotación; Ultrafino.

1. Introduction

Mineral processing of friable iron ores usually generates ultrafines particles under 15 μm , which can be called slimes. The concentration of this fraction presents technical challenges; thus, the slimes are preferentially disposed into tailings dams. Considering the high feed rate of the iron ore plants, it generates a large amount of slimes requiring a high footprint to be disposed into tailing dam. In a general overview, considering typical new projects of iron ore mineral processing plants, about 10 % to 20 % of the feed is discharged during the desliming stage (Mukherjee, 2015), which is commonly performed by hydrocyclones and thickeners.

In recent years, the mineral industry has researched to minimize the disposal of the slime fraction for some reasons, one of which is to minimize the volumes of tailings destined for dams, a fact driven by the recent accidents of dam failures (Rodrigues et al., 2021; Reis et al., 2020). Another reason is improving the technological application of mining tailings generating development and added value (Paula Jr. & Oliveira, 2022). The increase in metallurgical recovery should be also mentioned, since this fraction has an adequate content for concentration.

During the last decades, many companies and researchers have been trying to improve the ultrafines iron particles recovery using the conventional concentration methods, including gravity separation, magnetic concentration and froth flotation, however those methods have low selectivity in this size fraction. The inefficiency of those conventional methods is caused by low particle inertia, relatively higher deleterious drag forces, and very significant increase of surface (interface) phenomena. Flotation is very influenced by slime coating which can result in lower selectivity in the adsorption of reagents. The ultrafines also cause high consumption of reagents due to its high specific surface area, in addition these particles can be entrapment in the froth interstices resulting in lower content of the concentrate (Roy, 2009; Chen et al., 2016; Tammishetti et al., 2012). Chemical changes on surface of tiny particle in flotation systems are another concern, especially when dealing with sulfides. (Gaudin et al., 1931).

Flotation is usually applicable to concentration of particles under 150 μm . In addition, this technique has yet another limitation related to commonly composition of the slimes, most of which have considerable content of clay minerals. Although selective reverse cationic flotation works well for liberated contaminant-ores besides silica, the presence of aluminosilicates tends to drastically reduce the quality of the separation (Shaoo et al., 2016). As various clay minerals tend occur in natural fines, concentration by flotation is even more difficult.

Selective flocculation is an alternative to the conventional operations (Song & Lopez-Valdivieso, 2002). Progress in understanding the inherent fine particle phenomena and consequent process development have been achieved gradually, usually through studies using synthetically mixed samples, with focus on the screening of several reagents (Pradip et al. 1993; Ravishankar et al., 1995; Drzymala et al., 1981; Krishnan et al., 1983; Subramanian & Natarajan, 1990). Among the reagents studied are sodium silicate (water glass), sodium hexametaphosphate and polyvinyl pyrrolidone as dispersants, while starch is utilized as a flocculant (Weissenborn et al., 1995; Ma, 2012).

Commonly, such evaluations were made on variables such as ion concentration in water, water temperature and intensity of slurry agitation in fundamental studies (Arol and Iwasaki, 2003; Weissenborn et al., 1995; Haselhuhn & Kawatra, 2015; Haselhuhn et al., 2012). As a result, these works have been enabling the application of selective flocculation to ores of complex composition. There are several studies concerning selective flocculation of the hematite in slimes in presence of aluminosilicates and silicates (Singh & Singh, 1997; Pradip et al., 2013; Tammishetti et. al, 2017; Kumar & Mandre, 2016).

Currently, Tilden Plant, the largest industrial operation using the selective flocculation of iron ore fines (about 85 % less than 25 μm), applies reverse floc-flotation, in which the selectively dispersed phase composed of gangue is floated (Colombo, 1980; Luz, 2015). Although the established process utilizes floc-flotation, several studies have investigated selective flocculation as a single step for concentration, with good recovery and increase of iron content in the concentrate. These preconized routes usually do not include a floc-flotation step, a process that could further increase the metallurgical recovery and concentrate grades. This article shows the benefits of join selective flocculation and flotation.

In iron ore processing plants, desliming stage is performed prior to flotation with the purpose to improve the selectivity of the concentration. If it is possible to flocculate part of the slime separately, the flocculated mass could be fed directly to the flotation circuit, which would lead to a desirable increase in production. This work falls within this context. Different reagents and pulp conditions were studied aiming to verify the amenability of two typical ultrafine tailings from the so-called Brazilian Iron Quadrangle to the floc-flotation process. In order to achieve this objective, a simple device was designed to perform a campaign of selective flocculation of slime samples with subsequent flotation.

2. Methods and Results

2.1 Characterization of the samples

Slime samples from Conceição II (CEII) and Vargem Grande II (VGII) plants were collected from the underflow of the slime thickener of each plant, as indicated in Figure 1.

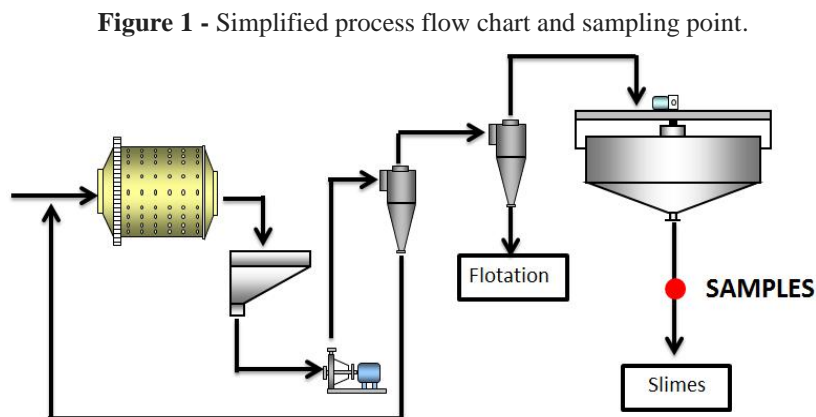

Source: Authors' own elaboration.

The particle size distribution (Figure 2) of the slime samples was determined by Cilas particle analyzer (1064 model). The determination of the specific surface area, made by nitrogen adsorption according to the BET isotherm in a Nova 1200e surface area analyzer, indicated 7,100 m^2/kg and 8,600 m^2/kg for CEII and VGII samples, respectively.

Classical nonlinear regression techniques were applied to test the goodness of fit of some theoretical statistical distributions, like Weibull-Rosin-Rammler, Hill and Harris. Harris distribution (a generalization of Gaudin–Meloy and Gates–Gaudin–Schumann) had high goodness of fit for both slime samples. This distribution is given by Equation (1):

$$Y = 1 - \left[1 - \left(\frac{x}{x_{max}} \right)^a \right]^b \quad (1)$$

Where Y is the cumulative passing fraction through the aperture x (expressed in this in the same unit as the top size, x_{max}). The experimental data and theoretical distribution (solid curves) are displayed in Figure 2 and their respective regression parameters are presented in Table 1. The last line of the table shows that the particle sizes of the samples CEII and VGII are slightly smaller than the corresponding feed of the floc-flotation circuit at Tilden plant (previously mentioned).

X-ray fluorescence chemical analysis was performed to determine the contents of several chemical components (Table 2).

Table 1 - Regression parameters for the Harris distribution.

Sample	CEII (Triangles in Figure 2)	VGII (Circles in Figure 2)
Top size (x_{max}):	45 μm	55 μm
Parameter a :	0.900	0.743
Parameter b :	2.5014	2.2065
Coefficient of determination (R^2)	0.99908	0.9975
85 % below:	22.3 μm	26.2 μm

Source: Authors' own elaboration.

Figure 2 - Particle size distribution of CEII (triangles) and VGII samples (circles).

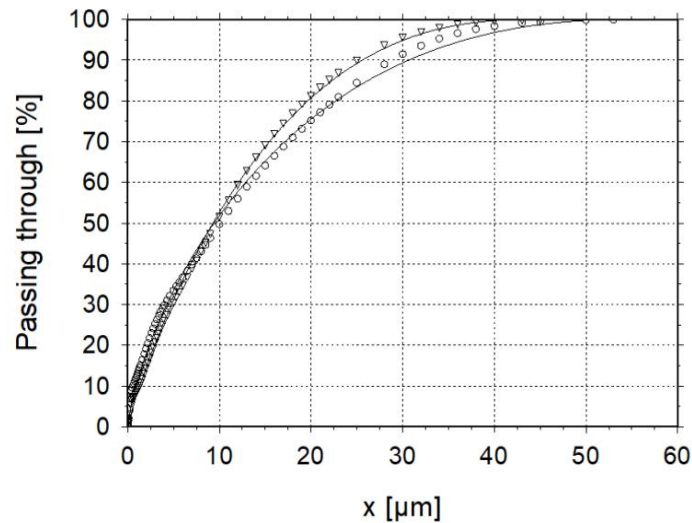

Source: Authors' own elaboration.

Table 2 - Chemical analysis samples from CEII and VGII (note: LOI stands for loss on ignition).

Sample	Fe	SiO ₂	Al ₂ O ₃	Mn	P	CaO	MgO	TiO ₂	LOI
CEII	37.18 %	34.73 %	4.61 %	0.34 %	0.11 %	0.19 %	0.75 %	0.11 %	5.70 %
VGII	43.87 %	28.91 %	2.49 %	0.10 %	0.11 %	0.01 %	0.07 %	0.10 %	5.36 %

Source: Authors' own elaboration.

The relative percentage of mineral phase was determined by using X-ray diffractometry, with the Rietveld refinement (which minimizes the difference between a crystallographic theoretical model and experimental data, via an approach of nonlinear least squares). The results are shown in Table 3. It can be highlighted that there are significant differences in the mineralogical composition of the samples. While the material from CEII has 20.2 % of kaolinite, the sample from VGII displays only 0.8 % of that mineral. On the other hand, the iron mineral of the sample from CEII is hematite, while goethite is also present

in the sample from VGII. The densities (or specific masses) were obtained by helium pycnometry, and showed the following figures: 3,820 kg/m³ and 4,040 kg/m³ for CEII and VGII samples, respectively. The higher specific weight for VGII is coherent with a higher grade of Fe 43.8 % (Table 2). Warning should be made that mineralogical quantification by X-ray diffractometry, even if using Rietveld's algorithm, is very prone to uncertainties. As an example, see the theoretical densities of the samples (last column of Table 3), calculated from the proportions shown in that table, which differ from the values obtained by helium pycnometry.

Table 3 - Mineralogical analysis of the samples from CEII and VGII.

Sample	Quartz	Hematite	Kaolinite	Goethite	Theoretical density
CEII	40.4 %	39.3 %	20.2 %	0.0 %	3,267.5 kg/m ³
VGII	48.6 %	46.4 %	0.8 %	4.2 %	3,466.8 kg/m ³

Source: Authors' own elaboration.

Complexometric titration with ethylene diamine tetra acetic acid (EDTA) was used to determine the concentration of calcium and magnesium ions in the process water, as they were potentially deleterious to selective flocculation (Ma, 2012; Haselhuhn and Kawatra, 2015). The concentrations were 7.3 mg/L for Ca²⁺ and 4.0 mg/L for Mg²⁺ for the slime from CEII and, on the other hand, 4.8 mg/L for Ca²⁺ and 4.5 mg/L for Mg²⁺ for the VGII slime. The results confirmed that the process waters, from both industrial plants, have acceptable concentrations of the cations for selective flocculation.

2.2 Selective flocculation and concentration tests

The reagents used were NaOH, HCl, sodium metasilicate (Na₂SiO₃, labeled hereafter SS) and sodium hexametaphosphate ((NaPO₃)₆, labeled SHMP) from Synth, and polyvinylpyrrolidone (PVP) from Sigma Aldrich. The average molecular mass of PVP was 360,000 g/mol). Corn starch was also used, having been prepared according to the procedure described by Lien & Morrow (1978). Selective flocculation tests were done in a specific vessel (Figure 3). The experiments were performed with 7 % of solids by mass (which corresponds, in volume basis, to 1.93 % for sample CEII and 1.82 % for sample VGII). A stainless steel three bladed pitched impeller was employed for agitation. Each of the blades was a curvilinear-based isosceles triangle (concave), with a height of 30 mm, welded horizontally on a stainless-steel disk with a diameter of 20 mm. The base angles were approximately 65 degrees and the blade tip had vortex of 50 degrees, with a twist (torsion) of approximately 30 degrees. Therefore, the effective impeller's turning diameter was $d_i = 100$ mm. The impeller off bottom clearance was kept at $C = 15.0$ mm (height above the bottom, as cylindrical part is considered). The agitator axis setup was axisymmetrical.

The sample was added into the vessel, and the plant's process water, at pH previously adjusted, was added to correct the desired mass solid concentration. Next, the dispersant was added (if any), and the suspension was conditioned for $\tau = 120$ s under vigorous stirring rate with angular velocity about 350 rpm (0.928 rad/s), shear rate (between impeller tip and vessel wall) was $\gamma = 73.30$ /s, resulting a Camp number $C^* = \tau\gamma = 8,796.5$. After the first conditioning stage, the stirring rate was decreased to 150 rpm (0.398 rad/s), and the flocculant was added gradually over 60 s. In sequence, the suspension was conditioned again for 90 s. In this step the shear rate was 31.42/s, resulting a Camp number $C^* = 2,827.4$.

After conditioning, the bottom outlet valve of the flocculation vessel was opened; the suspension was transferred to a vessel in which the sedimentation was allowed for 180 s. Next, dispersed (supernatant) and settled phases were removed separately. Both products were dried and weighed. Dispersed and settled solid material were submitted to chemical analysis.

Figure 3 - Unbaffled vessel used for selective flocculation experiments.

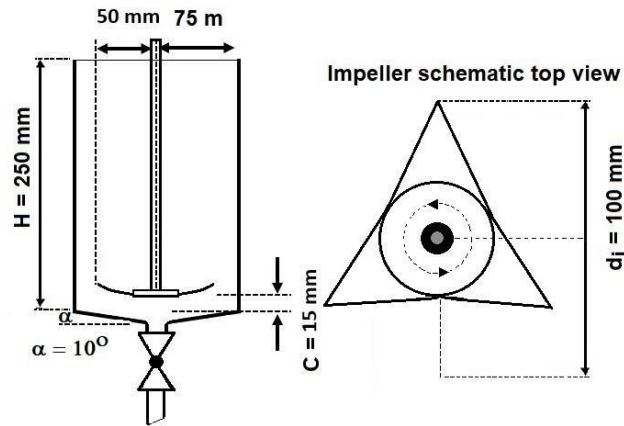

Source: Authors' own elaboration.

Reverse cationic flotation experiments, with and without prior flocculation, was performed. Gelatinized corn starch was used as depressant of the iron-bearing minerals. The gelatinization process was carried out under concentration of 1 % (w/v), and the corn starch to caustic soda mass ratio was 2:1. Flotigam EDA[®] from Clariant, at 2 % (w/v), was used as collector and frother. This collector is an alkyl ether mono-amine, partially neutralized by ethanoic acid. The nominal composition of Flotigam EDA is expressed by the following structural formula: $(CH_3)-(CH_2)_9-O-(CH_2)_3-NH_2$ (nominal molar mass of 215,14).

The flotation tests were conducted in a 1-liter CFB-1000 mechanical cell, from Cimaq S. A. The mass percentage of solids was 20 %, the pH adopted was 10.5. The starch dosage was 500 g/t, and the dosage of Flotigam EDA was 500 g per ton of SiO_2 fed. The starch conditioning time was 300 s. Subsequently, the conditioning time in amine solution was 120 s. The floated material was collected until the froth was exhausted. Figure 4 illustrates the sequence used to compare flotation of ultrafines and floc-flotation.

The influence of pH on the stability of the system was investigated. Figure 5 shows the impact of the pH on aggregation/dispersion of the system, it can be seen that the VGII slime is more affected than CEII by pH variation. The highest dispersion degree, occurred at pH 10.5 for both slimes, which showed smaller mass recovery. The higher dispersion of CEII sample, evidenced by lower mass recovery, may be related to the greater presence of kaolinite (20.2 %), which usually occurs at fine size distribution and show lower sedimentation rate.

Figure 4 - Comparative diagram of flotation and floc-flotation tests.

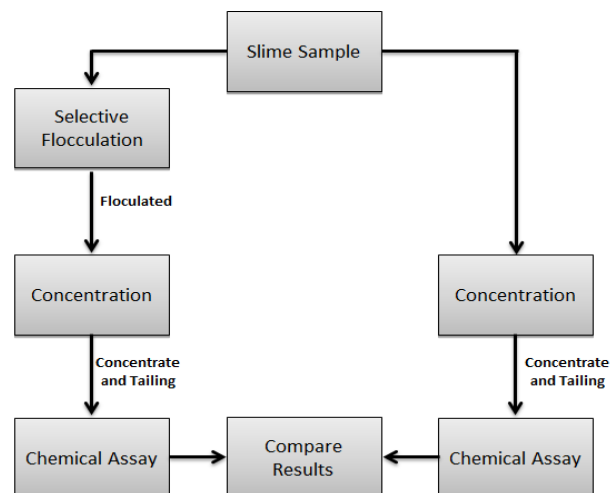

Source: Authors' own elaboration.

Figure 5 - Mass recovery as a function of pH for CEII and VGII slimes.

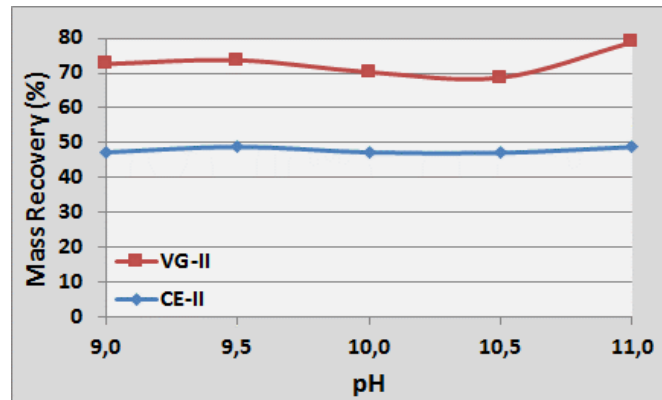

Source: Authors' own elaboration.

Figure 6 shows the use of dispersants has caused different results according to the slime type. CEII showed higher stability in the presence of high dosages (above 10 g/t) of polyvinyl pyrrolidone, which resulted in lower mass recovery. Sodium silicate and sodium hexametaphosphate did not have significant impact, even at high consumption.

Regarding VGII, the use of dispersants (in the same range of dosages used for CEII) did not increase significantly the dispersion of the samples. Therefore, for VGII, the dispersants were not used in the flocculation tests.

The addition of the gelatinized corn starch resulted in a considerable increase in the mass recovery, which points toward flocculation of the slime samples (Figure 7). The selective flocculation tests were done without dispersant for the VGII samples, and with 30 g/t of PVP for the CEII samples. For the last sample, the increase of the mass recovery wavered depending on the dosage of corn starch, it occurred for the range evaluated. Without flocculant the mass recovery was 18.7 %, with flocculant the mass recovery achieved 52.8 % at of starch unit consumption of 750 g/t. It should be highlighted the iron grade on the sunk (43.8 %), and the recovery of iron (52 %) at the dosage of 50g/t for corn starch. The iron grade at 750 g/t dosage of corn starch was, approximately, 38.5 %.

VGII slime had not shown a significant increase in the iron content of the sunk. Nevertheless, it stands out that in the presence of 1,000 g/t of starch, the mass recovery achieved 82.3 %, indicating the occurrence of flocculation.

Figure 6 - Mass recovery as a function of the unit consumption (dosage) of SS, SHMP or PVP for sample CEII.

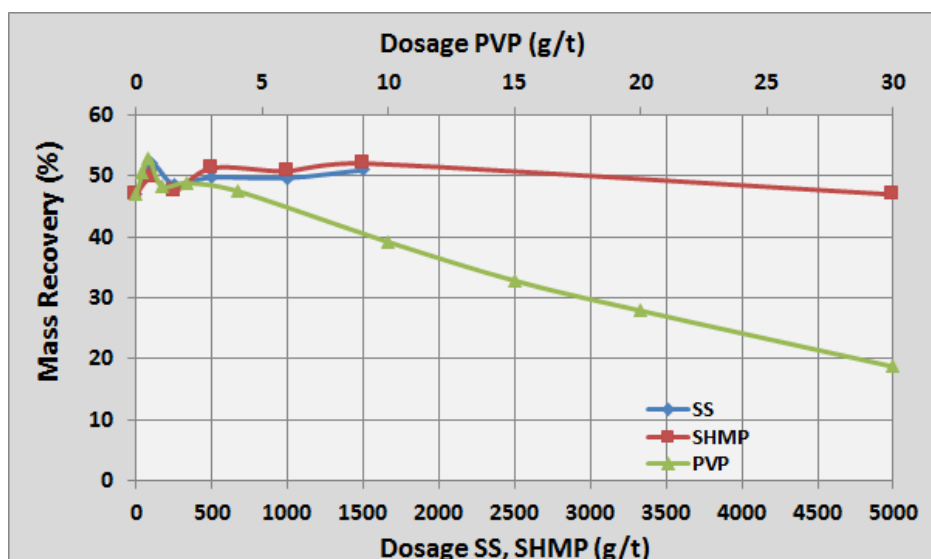

Source: Authors' own elaboration.

Figure 7 - Mass recovery as a function of dosage of gelatinized corn starch.

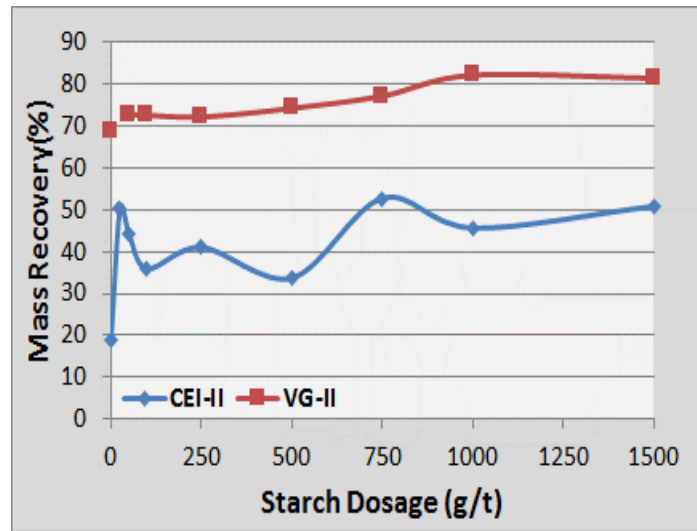

Source: Authors' own elaboration.

After all, the following conditions were considered the most promising to perform the floc-flotation experiments: (i) for CEII: 30 g/t of polyvinyl pyrrolidone, 50 g/t of gelatinized corn starch; (ii) for VGII: without dispersant, 1,000 g/t of gelatinized corn starch.

As exposed, the selective flocculation of the samples did not achieve satisfactory selectivity. Because of this, the sunk products from the flocculation experiments were then subjected to flotation tests. Metallurgical recovery of iron, contents of alumina and silica of the tailings and concentrate are shown in Table 4. SI stands for Gaudin's selectivity index.

Table 4 - Results of flotation with and without previous selective flocculation.

Sample	Selective Flocculation	Mass Recovery [%]	Recovery Fe [%]	SI	Concentrate			Tailing		
					Fe [%]	SiO ₂ [%]	Al ₂ O ₃ [%]	Fe [%]	SiO ₂ [%]	Al ₂ O ₃ [%]
CEII	No	51.0	39.1	1.37	46.95	24.23	3.92	31.56	44.73	5.75
CEII	Yes	36.5	71.3	2.53	52.01	19.32	2.57	21.73	58.42	6.11
VGII	No	61.7	77.1	3.96	54.84	15.02	2.34	26.18	58.10	2.78
VGII	Yes	64.5	87.9	6.58	60.59	9.46	1.51	13.49	77.47	1.45

Source: Authors' own elaboration.

The classical Gaudin's selectivity index is defined as the geometric mean of the relative recovery for ore mineral and the relative rejection for gangue, that is to say:

$$SI = \sqrt{\frac{R_{met} \cdot (1 - R_{met.g})}{R_{met.g} \cdot (1 - R_{met})}} \quad (2)$$

In the preceding equation, R_{met} and $R_{met.g}$ are the metallurgical recoveries for the ore mineral and the gangue, respectively. It is noteworthy that the selectivity index was calculated considering all ore minerals as hematite (Fe₂O₃), for simplicity; which does not in any way invalidate the conclusions, since hematite is the iron-bearing mineral vastly majority in samples.

It can be observed a significant improvement in selectivity index and iron content in the sunk product (concentrate), as well as in the iron recovery for both slimes. Highlighted the result for VGII with previous selective flocculation, the final

concentrate achieved 60.6 % of Fe, the mass recovery was 64.5 % and 13.5 % of Fe in the tailing. The samples were subjected to one stage of selective flocculation and one stage of flotation.

Apparently, the level of turbulence in the flotation cell, associated with the reagents and the air flow rate, led to a cleaning of the flakes. Ravishankar et al. (1995) reported the use of starch as flocculant does result in compact and strong flakes. Araujo et al. (2005) corroborate to Ravishankar et al. (1995) when they affirm that flocculation by starch gave rise to the formation of flakes with higher iron content. These flakes are hydrophilic in nature, also due to the presence of starch, a well-known iron oxide depressant. The results of floc-flotation (Table 4) indicated the stability of the flakes, even with the turbulence in the flotation cell.

3. Conclusions

Slimes from CEII and VGII were characterized. Both samples presented d_{80} equal 25 μm . CEII slime presents kaolinite as an important contaminant (20 %), whereas that the VGII slime presents goethite in small amount (4 %).

Complexometric titration has shown that the process waters, from both slimes, have suitable concentrations of calcium and magnesium ions for selective flocculation: 7.3 mg/L Ca^{2+} , 4.0 mg/L Mg^{2+} for CEII, and 4.8 mg/L Ca^{2+} , 4.5 mg/L Mg^{2+} for VGII.

Only selective flocculation, even under optimized conditions, did not achieve good results in terms of selectivity. However, the selective flocculation prior to flotation has led to promising results, especially for VGII, the final concentrate achieved 60.6 % of Fe, the mass recovery was 64.5 % and 13.5 % of Fe in the tailing.

Acknowledgement

The authors are grateful to the Brazilian Council for the Technological and Scientific Development (CNPq), Foundation for Research Support of the State of Minas Gerais (FAPEMIG), Brazilian Federal Agency for Support and Evaluation of Graduate Education (CAPES), and Vale Institute of Technology (ITV) for supporting this research. The authors also take the opportunity to declare that there is no conflict of interest regarding the publication of this article

References

- Araujo, A. C., Viana, P. R. M., & Peres, A. E. C. (2005). Reagents in iron ores flotation. *Minerals Engineering*, 18, 219-222.
- Arol, A. I., Iwasaki, I. (2003). Effect of sodium silicate on flocculation of hematite with starch in the presence of calcium. *Separation Science and Technology*, 38(3), 647-659.
- Chen, T., Su, T., Zhang, Y., & Hu, P. (2016). Selective Flocculation Enhanced Magnetic Separation of Ultrafine Disseminated Magnetite Ores. *Minerals*, 6, 86.
- Colombo, A. F. (1980). *Selective flocculation and flotation of iron bearing minerals: Fine Particles Processing.*: AIME.
- Drzymala, J., & Fuerstenau, D. W. (1981). Selective flocculation of hematite in the hematite-quartz-ferric ion-polyacrylic acid system - Part 1, Activation and Deactivation of Quartz, *International Journal of Mineral Processing*, 8, 265-277.
- Gaudin, A. M., Groh, J. O., & Henderson, H. B. (1931). Effect of particle size on flotation, *AIME, Tech. Publ.*, 414, 3-23.
- Haselhuhn, H. J.; Carlson, J. J., & Kawatra, S. K. (2012). Water chemistry analysis of an industrial selective flocculation dispersion hematite ore concentrator plant. *International Journal of Mineral Processing*, 102-103, 99-106.
- Haselhuhn, H. J., & Kawatra, K. (2015). Effects of Water Chemistry on Hematite Selective Flocculation and Dispersion. *Mineral Processing & Extractive Metallurgy Review*, 36, 305-309.
- Krishnan, S. V., & Iwasaki, I. (1983). Sodium silicate as a dispersant in selective flocculation of iron ores. *Trans. SME-AIME*, 272, 1984-1988.
- Kumar, R., & Mandre, N. R. (2016). Beneficiation of iron ore slimes using a natural polymer by selective flocculation process. *International Seminar on Mineral Processing Technology*. Pune, India. 421-428.
- Lien, H. O. & Morrow, J. G. (1978). Beneficiation of lean iron ores solely by selective flocculation and desliming. *CIM Bulletin*, 71 (798), 109-120.

- Luz, J. A. M. (2015). Encyclopedia of Iron, Steel, and Their Alloys: *Flotation of Iron Ore*. Bosa Roca: Taylor & Francis Group.
- Ma, M. (2012). The dispersive effect of sodium hexametaphosphate on kaolinite in saline water. *Clays and Clays minerals*, 60, 405-410.
- Mukherjee, A. K., Thella, J. S., Makhija, D., Patra, A. S., Manna, M., & Ghosh, T. K. (2015). Process to Recover Iron Values from High-Alumina Indian Iron Ore Slime – a Bench-Scale Study. *Mineral Processing & Extractive Metallurgy Review*, 36, 39-44.
- Paula Jr., W. R.de, Oliveira, C. A. S. (2022). Avaliação da utilização do rejeito de minério de ferro na formulação de argamassas. *Research, Society and Development*, 11(4), e0211425954. 10.33448/rsd-v11i4.25954.
- Pradip, Ravishankar, S. A., Sankar, T. A. P., & Khosla, N. K. (1993). Beneficiation Studies on Alumina-Rich Indian Iron Ore Slimes using Selective Dispersants, Flocculants and Flotation Collectors. *XVIII International Mineral Processing Congress*, Sydney, Australia, 1289-1294.
- Pradip, Rai, B., Waghmare, U. V., & Tammishetti, V. (2013). Processing of Alumina-Rich Iron Ore Slimes: Is the Selective Dispersion Flocculation Flotation the Solution.... *Transactions of the Indian Institute of Metals*, 66(5-6), 447-456.
- Ravishankar, S. A., Pradip, & Khosla, N. K. (1995). Selective flocculation of iron oxide from its synthetic mixtures with clays: a comparison of polyacrylic acid and starch polymers. *International Journal of Mineral Processing*, 43, 235-247.
- Reis, D. A. Dos, Marques, L. De S., Nascimento, L. P. Do, Santiago, A. Da F. (2020). Potencial de risco dos sedimentos de fundo afetados por rejeitos de mineração oriundos da barragem de Fundão/ Brasil. *Research, Society and Development*, 9(7), e611974041. 10.33448/rsd-v9i7.4041.
- Rodrigues, H. C. T., Santos, P. S., Carneiro, F. S., Amaral, A. P. M., Pinheiro, A. O., Maestri, M. P., Amorim, M. B. (2021). Risk analysis of the iron ore dam in the Northern Mountains in Pará. *Research Society and Development*, 10(13), e326101318611. 10.33448/rsd-v10i13.18611 1
- Roy, S. (2009). Recovery Improvement of Fine Iron Ore Particles by Multi Gravity Separation. *The Open Mineral Processing Journal*, 2, 17-30.
- Singh, B. P., & Singh, R. (1997). Investigation on the Effect of Ultrasonic Pretreatment on Selective Separation of Iron Values from Iron Ore Tailings by Flocculation. *Separation Science and Technology*, 32(5), 993-1002.
- Shaoo, H., Rath, S. S., Rao, D. S., Mishra, B. K., & Das, B. (2016). Role of silica and alumina content in the flotation of iron ores. *International Journal of Mineral Processing*, 148, 83-91.
- Song, S., Lopez-Valdivieso, A. (2002). Parametric aspect of hydrophobic flocculation technology. *Mineral Processing and Extractive Metallurgy Review*, 23, 2, pp. 101-127.
- Subramanian, S., & Natarajan, K. A. (1990). Flocculation, filtration and selective flocculation studies on hematite ore fines using starch. *Minerals Engineering*, 4, 587-598.
- Tammishetti, V., Joshi, K., Rai, B., & Pradip. (2012). Selective Dispersion – Flocculation of Alumina Rich Iron Ore Slimes. *International Mineral Processing Congress*, 26, 24-28.
- Tammishetti, V., Kumar, D., Rai, B., Pradip, Shukla, V., Patra, A. S., Hakraborty, D. P., & Kumar, A. (2017). Selective Flocculation of Iron Ore Slimes: Results of Successful Pilot Plant Trials at Tata Steel, Noamundi. *Transactions of the Indian Institute of Metals*, 70(2), 411-419.
- Weissenborn, P. K., Warren, L. J., & Dunn, J. L. (1995). Selective flocculation of ultrafine iron ore. *Colloids and Surfaces A: Physicochemical and Engineering Aspects*, 11-27.